

ALD6720S 3D SPI SYSTEM

GREAT PERFORMANCE, SIMPLE OPERATION

- ▶ Precise measurement simultaneously in 2D and 3D
- ▶ Automatic real-time warpage compensation
- ▶ Programming time of less than 5 min
- ▶ Training time less than 1 hour
- ▶ Fast inspection
- ▶ Exceptionally high MTBF



THE BEST SOLUTION FOR HIGH LEVEL SMT LINES

The unique optical system developed by ALeader delivers an accurate, reliable 3D measurement and top-quality high-resolution 2D image

- Bi-directional structured light (advanced phase-shifting digital projection system, developed in-house)
- Multi-directional (360° horizontal, 0-90° vertical) LED illumination system
- High-speed camera



Simultaneous 2D and 3D inspection guarantees full inspection coverage with the most accurate measurement of the paste deposits height, area and volume

The superior high-resolution image, generated by the high-speed camera and the unique lighting system, clearly distinguishes between the pastes, pads, silkscreen and the board.

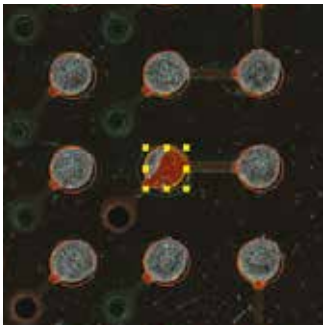

Precise height measurement based on Phase Measurement Profilometry (PMP). Bi-directional phase shifting projection system ensures accurate and noise resistant measurement of the paste height and volume.

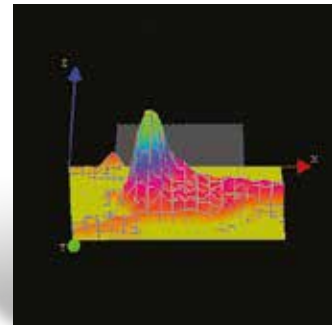

Innovative, real-time automatic warpage compensation and measurement floor recognition method. The system identifies the pads as a zero level for the paste height measurement for each board and FOV. Such a capability completely eliminates the influence of PCB warpage on the inspection result. The process is completely automatic and user-independent, no bare board or any special procedures are required.

PCB warpage does not affect the measurement result, system provides precise paste height from the pad level

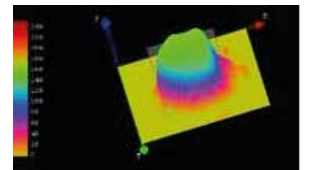

FOV uniformity

Over 90% brightness uniformity across the FOV. High measurement accuracy is consistent throughout all parts of the PCB

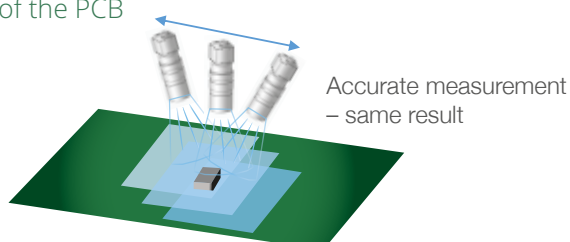

Insensitivity to PCB color

ALeader's SPI advanced optical system guarantees the same superior level of performance on PCBs of any color



Easy and fast, wizard based programming

- Less than 5 min to start production for a new product, with a friendly and intuitive user interface.
- Takes less than an hour to train a new user to program and operate the system.
- Possible to create a program without Gerber using a good board sample only (auto programming).
- Global quality settings based on paste size and stencil thickness are automatically adopted for each new program, delivering the same high-quality programs despite having been written by a different user.



Structured and clearly defined access level

- Operator – Production, Process
- Programmer – Production, Process, Setup
- Administrator – Production, Process, Setup, Config, HW and Diagnostic



Real-time built-in SPC as a standard

- Height map for each PCB
- Real-time monitoring charts for height, volume, area and offset
- History review and analysis

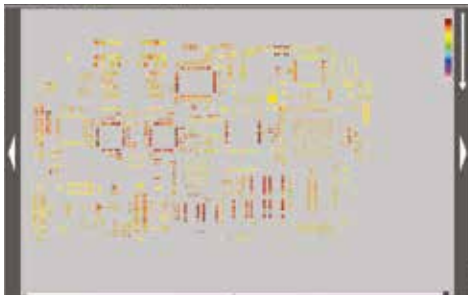

Alerts and feedback for continuous printing process improvement

Communication with the pick and place systems

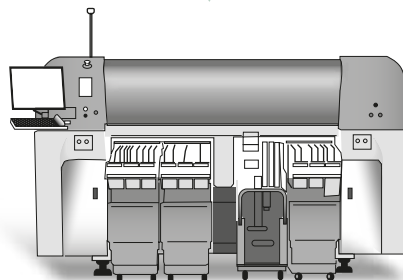
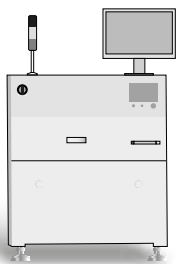

- Closed loop with the printer
- Communication with the P&P
- Alerts

Functional specification	
Inspection method	Phase Measurement Profilometry
Camera	5M pixel high-speed camera. Telecentric lens
Lighting system	Top and 360° steep LED light; bi-directional structured light projection
Program creation	Import Gerber (274X, 274D) file , auto programming (w/out Gerber)
Inspection coverage	Volume, area, height, offset, insufficient, excessive, bridge, joint, contamination, etc...
Operation system	Windows 10 Professional 64 bit
Inspection board specification	
PCB type	All colors and all pad finishes
PCB size range	Min 50mm x 50mm, Max 510mm x 500mm (ALD6720S) 620mm x 550mm (ALD6730S) 1500mm x 450mm (ALD6750S) 620mm x 300mm double line (ALD6730D)
PCB thickness range	0.2mm to 5mm
Clamping system edge clearance	Top 2.5mm, bottom 3mm
PCB weight	up to 3 kg
Underside/topside clearance	85mm/30mm
Min paste size	0.100mm x 0.100mm
Max paste size	10mm x 10mm
Max measurement height	1000μ
Min paste pitch	100μ
Inspection performance	
Resolution/ranges/speed	15μ/pixel FOV:36.00mm x30.72mm. Test speed<0.33 sec/FOV, about 1200 dots/sec
Height Resolution	0.37μ
Reproducibility	Height <1% at 3σ, Volume <1% at 3σ
GR&R	<10% at 6σ
Features and options	
Special features	Supports auto change program, multiboards and multiprograms inspection modes
Barcode system	Auto read barcode 1D and 2D. External reader reads back side barcode (option)
Server mode	Central server, multiple machines, data handling
Remote control	Remote control through TCP/IP for verification, system operation and program adjustment
Additional Options	SPC repair station, Offline program, External barcode scanner
Hardware	
Conveyor	Flat belt conveyor, automatic clamp (pneumatic), auto load and unload, automatic width adjustment
Conveyor direction/time	Screw and AC servo driver, precision 0.25μ; PCB fix, camera moves X/Y
X/Y driver	Left to right or right to left in/out time 4 sec
Power supply	AC230V 50/60Hz <1.5KVA
Compressed air	0.4-0.8 MPA
Equipment communication	SMEMA
Dimension and Weight	
Weight	920 kg
Dimensions	1085x1275x1570mm ALD6720S, 1200x1665x1570mm ALD6730S, 2200x1580x1570mm ALD6750S, 1200x1665x1570mm ALD6720D (LxWxH not including signal light tower height)
Conveyor height	870-970mm

Above specifications are subject to change without notice. Images used in the brochure are for illustrative purposes only

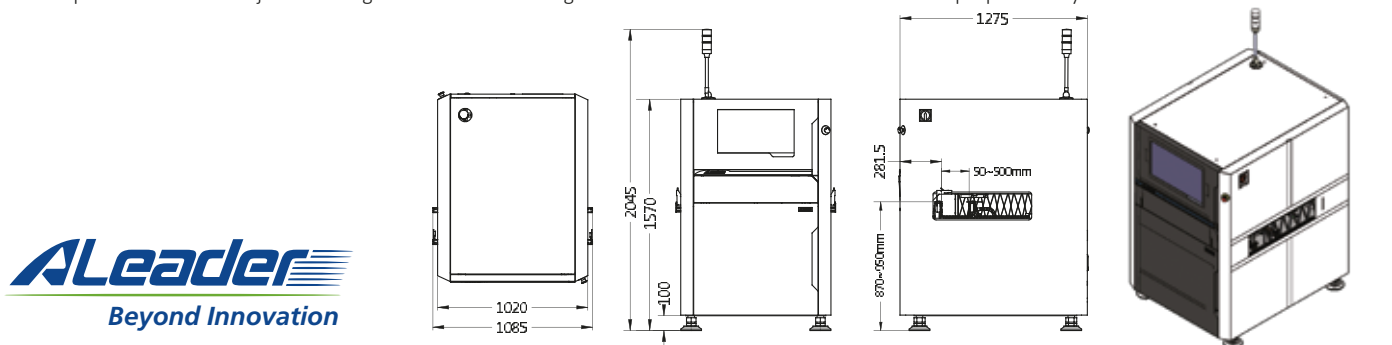

AL leader Europe Ltd.

International Marketing- Training Center - Support Center
Industrial Zone Netser Sereni 7039500, Israel
Tel: +972-89208844 Fax: +972-89207711 | www.aleader-europe.com

AL leader Vision Technology Co., Ltd.
Manufacturing

Dongguan city, Guangdong province 523128, China

